

Sigma swivelling tip dresser

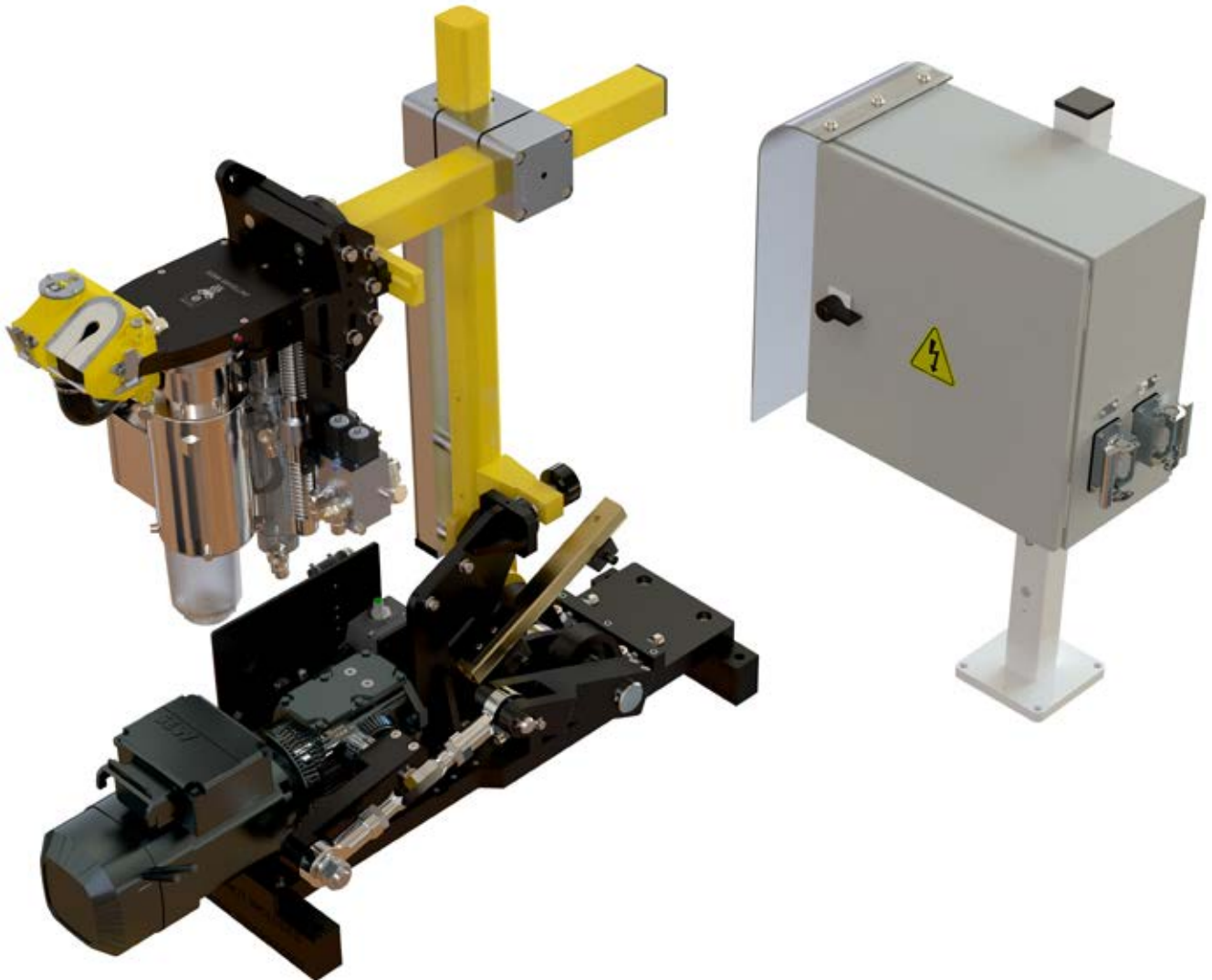

Features

Swivelling tip dresser for stationary welding guns

Very efficient chip suction with integrated Venturi system

Pneumatic compensation system

Mechanical adjustment of dressing head

Electric box according to the desired standard

Versions with additional arm available for offset increase

Technical data

Distance from the center of the gear to the end of the carter	39 mm
---	-------

Height of the head	20 mm
--------------------	-------

Cutter rotational speed	265 rpm
-------------------------	---------

Cutter rotation direction	Clockwise
---------------------------	-----------

Sigma series technical specifications

<i>Specifications</i>	<i>CEE South America Africa - India</i>	<i>China</i>	<i>USA</i>
Power	0,8 kW	0,8 kW	0,8 kW
Frequency	50/60	50	50/60
Power supply	Y 400-415 V Y 460-480 V } 50/60 Hz 2A	Y 400 VAC 50 Hz 2A	Y 400-415 V Y 460-480 V } 50/60 Hz 2A
Optional power supply	/	/	Δ 230-300 V 60 Hz 3.46A
Optional power supply	/	/	Δ 220-255 V 50 Hz 3.46A
Duty cycle	S3-7%	S3-7%	S3-7%
Certification	CE	CCC	AM-UL
Compressed air consumption	400 l/min	400 l/min	400 l/min
Compressed air supply	6 bar	6 bar	6 bar
IP protection level	55	55	55
Pipes and fittings	ISO	ISO	ISO
Solenoid valves	ISO	ISO	ISO